

TOP-QUALITY
PNEUMATIC ACTUATOR

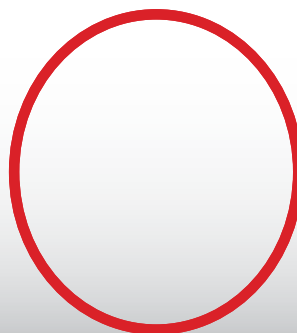

TOP-QUALITY

INNOBIZ
기술 혁신형 중소기업



INTRODUCTION

PDS series Pneumatic Actuators are designed using Scotch-Yoke technology from PDS 50 to the largest of PDS 200. Scotch-Yoke technology is well known to all users as the most suitable actuator mechanism for valve and damper operation as it produces higher torque at both end positions.

Specification of PDS actuators follow international standards for faster and easier mounting of accessories like Solenoid valves, limit switches, positioners etc.

Ranges available are 10Nm through 4000Nm double acting, and 5Nm through 1900Nm spring return.

The range of ambient temperature for standard operation is -20°C ~ 80°C as standard (For higher and lower temperature applications please consult manufacturer before placing order).

Mounting dimensions follow ISO5211, DIN3337, NAMUR, VDI/VDE3845 standards,

The drive shafts come in various sizes with double square shaped female bore for accomodating valve shaft,
Spring package is pre-compressed for increased safety,
Extremely long service life and reliable performance.

I-TORK Controls Ltd. also provides ITS series limit switch boxes (weather proof, explosion proof), solenoid valves, positioners for modulating services and other pneumatic accessories.

Side hand-wheel and de-clutchable gear box for manual operation are also options available in the I-TORK product range.



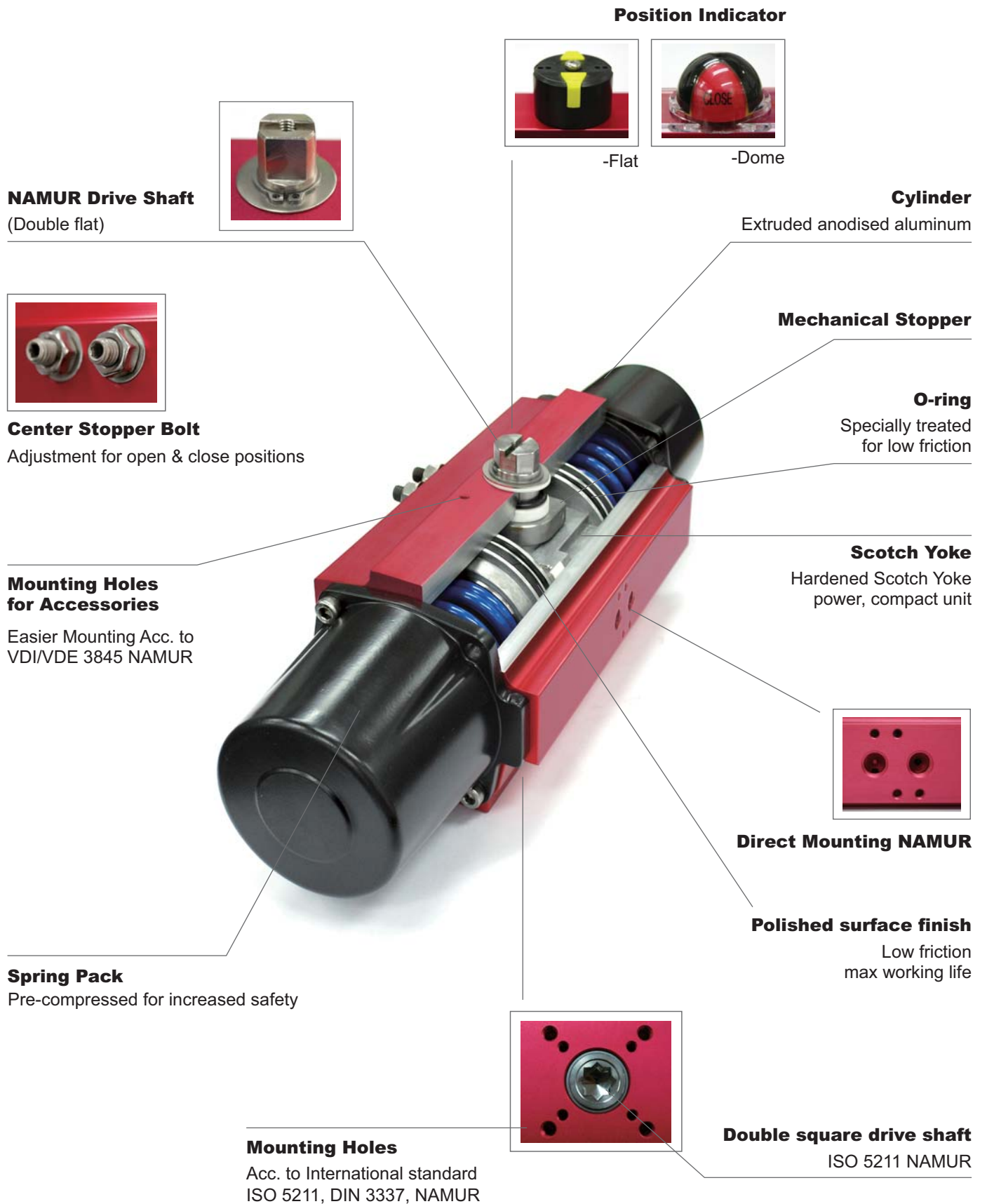

FEATURES AND ADVANTAGE



Advantage (Scotch Yoke)

The I-TORK actuators provide increased torque at open and close position, this closely matches the required torque for practical valve operation.

- Increased torque at the open and close position.
- Compact design and size
- Extremely long cyclic life
- Adjustable center stopper for both open & close positions

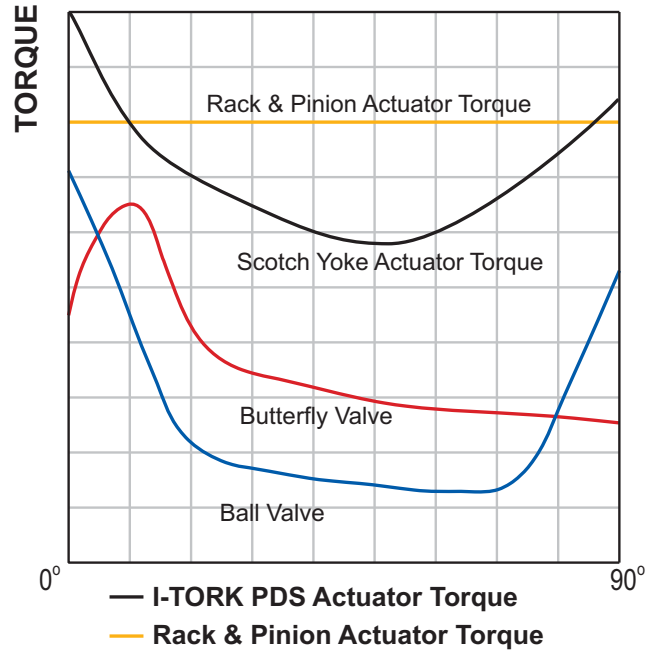

MECHANICAL MOVEMENT & POSITION INSIDE

DOUBLE ACTING

CLOSE

OPEN

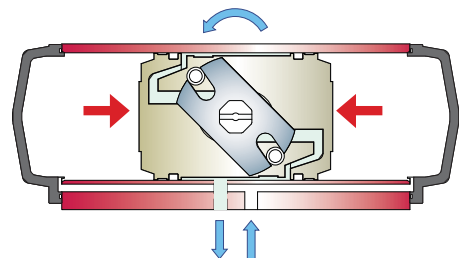
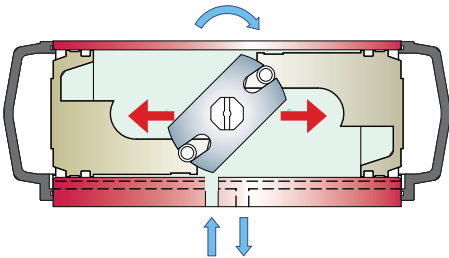

SPRING RETURN

CLOSE

OPEN

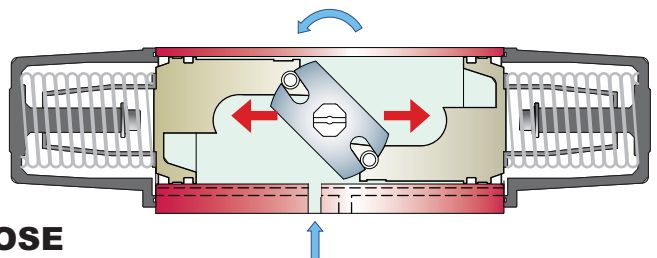
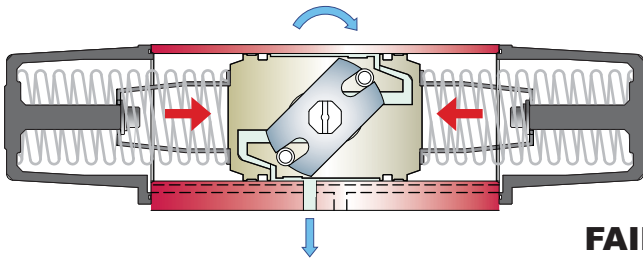

TECHNICAL INFORMATION

DOUBLE ACTING OUTPUT TORQUE (Nm)

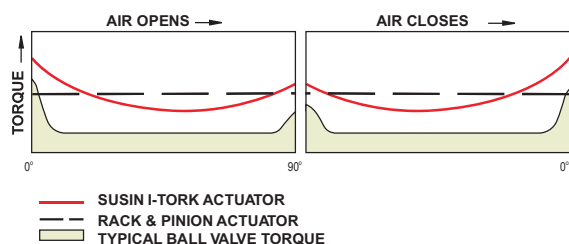

MODEL	Angle	2.8 bar 40 psi	3.5 bar 50 psi	4.2 bar 61 psi	5.5 bar 80 psi	6 bar 87 psi	7 bar 100 psi	8 bar 116 psi	Air Consumption (L, at 5.5 bar)		Operating Time (Sec., at 5.5bar)
									OPEN	CLOSE	
PD45	0°	12	16	20	26	28	34	38	0.12	0.12	< 0.3
	45°	5	7	9	11	12	14	16			
	90°	8	12	15	18	20	23	27			
PD50	0°	27	34	41	54	59	69	79	0.16	0.16	< 0.3
	45°	12	15	17	23	25	29	33			
	90°	19	24	29	38	42	48	55			
PD55	0°	27	45	56	73	80	94	107	0.34	0.34	< 0.4
	45°	15	18	23	30	33	37	44			
	90°	25	32	39	51	57	65	75			
PD70	0°	76	95	114	149	163	190	217	0.46	0.46	< 0.6
	45°	32	40	48	62	68	79	90			
	90°	53	66	78	104	114	133	152			
PD75	0°	112	141	170	223	243	284	324	0.99	0.96	< 0.5
	45°	47	58	70	93	101	117	134			
	90°	78	98	119	155	170	198	226			
PD85	0°	141	176	212	277	302	353	403	0.8	0.8	< 1.0
	45°	59	74	89	116	127	148	169			
	90°	99	123	148	194	212	247	282			
PD100	0°	229	286	343	449	490	571	653	1.32	1.28	< 2.0
	45°	96	120	144	188	205	239	273			
	90°	160	200	240	314	343	400	457			
PD125	0°	438	547	657	860	938	1,095	1,250	2.49	2.42	< 3.0
	45°	182	228	273	358	390	456	521			
	90°	306	383	460	602	657	766	876			
PD160	0°	850	1,062	1,274	1,668	1,820	2,124	2,427	4.52	4.61	< 5.0
	45°	355	444	533	698	761	888	1,015			
	90°	595	744	892	1,168	1,275	1,487	1,700			
PD200	0°	1,622	2,028	2,433	3,187	3,476	4,056	4,635	9.07	9.21	< 6.0
	45°	679	848	1,018	1,333	1,454	1,697	1,939			
	90°	1,136	1,420	1,704	2,231	2,434	2,840	3,245			

*Please be sure to include appropriate torque safety factors and variable service conditions when sizing.

TECHNICAL INFORMATION

SPRING RETURN OUTPUT TORQUE (Nm)

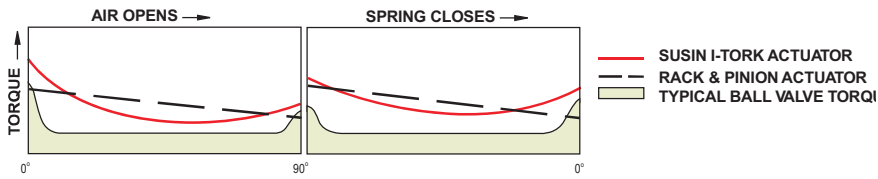

Spring Close

MODEL	Function	Angle	4.2 bar 60 psi	5.5 bar 80 psi	6 bar 87 psi	7 bar 100 psi	Air Consumption (L, at 5.5 bar)	Operating Time (Sec., at 5.5bar)
PS45	Air open	0°	12.0	17.1	18.5	20.5	0.12	< 0.3
		55°	4.0	5.1	5.8	6.4		
		90°	5.1	5.9	6.7	7.6		
	Spring close	90°	9.1	12.3	13.1	15.1		
		35°	4.3	5.5	6.5	7.3		
		0°	7.4	8.7	9.8	11.9		
PS50	Air open	0°	25.6	34.6	37.6	42.5	0.16	< 0.3
		55°	8.3	11.1	12.0	13.4		
		90°	10.0	13.1	14.2	15.4		
	Spring close	90°	18.6	25.0	27.3	32.2		
		35°	9.0	12.0	13.1	15.5		
		0°	15.2	19.9	21.7	25.6		
PS55	Air open	0°	33.1	45.1	48.4	55.2	0.34	< 0.4
		55°	11.0	13.7	14.9	16.9		
		90°	31.7	18.0	19.8	21.9		
	Spring close	90°	23.7	32.1	35.4	41.1		
		35°	11.9	16.2	17.6	20.8		
		0°	20.8	27.2	30.4	36.2		
PS70	Air open	0°	68.3	92.3	98.9	112.3	0.46	< 0.6
		55°	21.9	29.0	31.6	35.4		
		90°	29.0	38.0	41.7	46.2		
	Spring close	90°	49.5	66.7	72.1	84.6		
		35°	25.7	34.3	37.4	43.8		
		0°	43.8	57.2	63.6	74.6		
PS75	Air open	0°	106.4	141.7	154.2	178.1	0.96	< 0.5
		55°	31.5	41.8	45.1	53.2		
		90°	39.7	52.2	56.8	66.5		
	Spring close	90°	77.0	103.2	112.4	127.8		
		35°	37.8	51.2	55.8	64.2		
		0°	59.7	80.9	88.1	100.8		
PS85	Air open	0°	131.9	176.2	187.9	216.7	0.79	< 1.0
		55°	40.1	53.4	57.9	66.9		
		90°	50.4	67.0	72.5	83.9		
	Spring close	90°	95.7	127.8	139.3	159.5		
		35°	48.4	64.5	70.4	80.6		
		0°	76.7	101.9	114.6	131.0		
PS100	Air open	0°	214.6	286.8	311.2	359.6	1.28	< 2.0
		55°	64.7	86.1	93.4	108.4		
		90°	80.5	106.7	115.7	134.9		
	Spring close	90°	156.0	208.7	227.2	259.2		
		35°	78.6	104.9	114.3	130.3		
		0°	123.2	163.5	178.5	203.3		
PS125	Air open	0°	412.5	552.4	601.3	689.3	2.42	< 3.0
		55°	115.9	164.9	189.4	217.2		
		90°	132.3	202.8	247.1	283.4		
	Spring close	90°	320.7	401.1	409.7	471.5		
		35°	158.4	200.9	208.4	240.0		
		0°	234.2	309.8	336.4	388.5		
PS160	Air open	0°	802.5	1,075.6	1,189.6	1,373.0	4.61	< 5.0
		55°	239.6	319.5	341.8	395.8		
		90°	294.8	390.9	401.8	467.1		
	Spring close	90°	584.0	780.8	872.5	997.6		
		35°	292.7	390.2	429.9	491.3		
		0°	452.6	579.9	630.3	718.8		
PS200	Air open	0°	1,561.3	2,079.9	2,272.7	2,603.4	9.21	< 6.0
		55°	452.2	607.9	660.3	747.3		
		90°	536.6	729.5	786.7	877.1		
	Spring close	90°	1,141.7	1,508.2	1,646.9	1,920.1		
		35°	564.3	747.4	813.6	946.8		
		0°	835.6	1,115.9	1,202.8	1,391.4		

*Please be sure to include appropriate safety factors and various service conditions when sizing.

TECHNICAL INFORMATION

SPRING RETURN OUTPUT TORQUE (Nm)

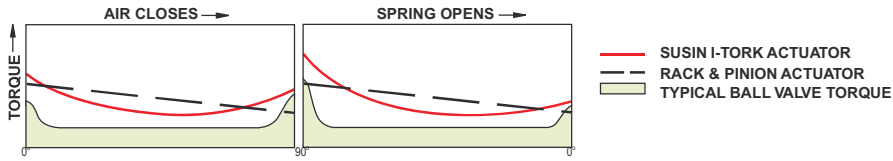

Spring Open

MODEL	Function	Angle	4.2 bar 60 psi	5.5 bar 80 psi	6 bar 87 psi	7 bar 100 psi	Air Consumption (L, at 5.5 bar)	Operating Time (Sec., at 5.5bar)
PS45	Air open	90°	7.9	11.75	12.85	14.5	0.12	< 0.3
		55°	3.9	5.12	5.78	6.24		
		0°	6.87	8.98	9.65	10.78		
	Spring close	0°	12.79	17.32	18.92	22.3		
		35°	3.9	5.1	5.78	6.45		
PS50	Air open	90°	17.9	24.2	26.3	29.8	0.16	< 0.3
		55°	8.3	11.1	12.0	13.4		
		0°	14.3	18.7	20.3	22.0		
	Spring close	0°	26.5	35.7	39.0	46.1		
		35°	8.3	11.0	12.0	14.1		
PS55	Air open	90°	22.78	31.2	33.46	37.8	0.34	< 0.4
		55°	10.65	14.6	15.2	17.65		
		0°	19.8	26.2	28.6	31.7		
	Spring close	0°	34.55	46.57	50.2	58.9		
		35°	10.8	14.4	15.78	17.9		
PS70	Air open	90°	47.8	64.6	69.3	78.6	0.46	< 0.6
		55°	22.7	30.4	32.8	36.9		
		0°	41.4	54.2	59.6	66.0		
	Spring close	0°	70.7	95.3	103.0	120.8		
		35°	22.9	30.3	33.3	39.0		
PS75	Air open	90°	73.85	98.75	107.54	124.8	0.99	< 0.5
		55°	33.1	43.45	48.26	56.3		
		0°	55.95	75.45	81.34	95.13		
	Spring close	0°	110.5	147.1	161.1	183.8		
		35°	32.9	44.15	48.12	55.23		
PS85	Air open	90°	92.4	123.4	131.6	151.7	0.8	< 1.0
		55°	42.3	56.4	61.2	70.6		
		0°	72.0	95.6	103.5	119.8		
	Spring close	0°	136.6	182.5	199.0	227.8		
		35°	42.1	56.1	61.2	70.0		
PS100	Air open	90°	150.3	200.8	217.9	251.8	1.32	< 2.0
		55°	68.5	91.3	99.1	114.8		
		0°	114.9	152.3	165.3	192.7		
	Spring close	0°	222.8	298.0	324.4	370.2		
		35°	68.2	90.9	99.0	112.9		
PS125	Air open	90°	288.8	386.8	421.0	482.6	2.49	< 3.0
		55°	125.6	175.2	191.1	219.1		
		0°	188.9	289.7	352.9	404.8		
	Spring close	0°	458.0	572.9	585.1	673.4		
		35°	135.1	173.5	189.4	218.3		
PS160	Air open	90°	561.9	753.1	832.9	961.4	4.52	< 5.0
		55°	254.5	339.9	367.7	425.3		
		0°	421.0	558.3	573.8	667.0		
	Spring close	0°	834.1	1115.1	1246.1	1424.8		
		35°	255.9	340.6	372.4	425.4		
PS200	Air open	90°	1093.2	1456.4	1591.3	1822.9	9.07	< 6.0
		55°	485.1	650.2	707.6	804.1		
		0°	766.4	1041.9	1123.5	1252.7		
	Spring close	0°	1630.5	2154.0	2352.0	2742.2		
		35°	481.5	639.3	693.9	806.1		
		90°	585.1	781.4	842.2	974.3		

*Please be sure to include appropriate safety factors and various service conditions when sizing.

DIMENSIONS

DOUBLE ACTING : PD Series

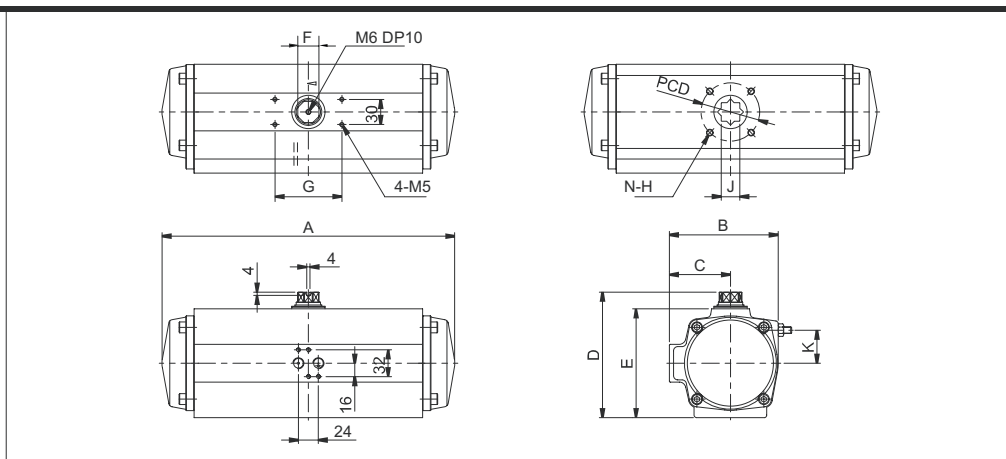

UNIT : mm

MODEL	A	B	C	D	E	F	G	ISO5211	PCD	N-H	J	DP	K	WEIGHT
PD45	159	73	42	91	71	11.4	80	F03/F05/F07	35/50/70	4-M5/M6	11X11	15	19.5	
PD50	186	73	42	91	71	11.4	80	F03/F05/F07	35/50/70	4-M5/M6	11X11	15	19.5	1.6
PD55	201	96	55	112	92	17	80	F05/F07	50/70	4-M6/M8	17X17	20	26	
PD70	255	96	55	112	92	17	80	F05/F07	50/70	4-M6/M8	17X17	20	26	3
PD75	270	130	73	150	130	25.4	80	F07/F10	70/102	4-M8/M10	22X22	30	39.5	
PD85	300	110	62	130	110	22	80	F05/F07	50/70	4-M6/M8	17X17	25	33	5
PD100	350	130	73	150	130	25.4	80	F07/F10	70/102	4-M8/M10	22X22	30	39.5	7.5
PD125	412	159	88	182	162	28.6	80	F10/F12	102/125	4-M10/M12	27X27	35	47.5	11
PD160	510	195	105	240	210	34	80/130	F10/F14	102/140	4-M10/M16	36X36	60	62	26
PD200	625	243	130	292	262	42.5	80/130	F12/F16	125/165	4-M12/M20	46X46	60	77.5	43

SPRING RETURN : PS Series

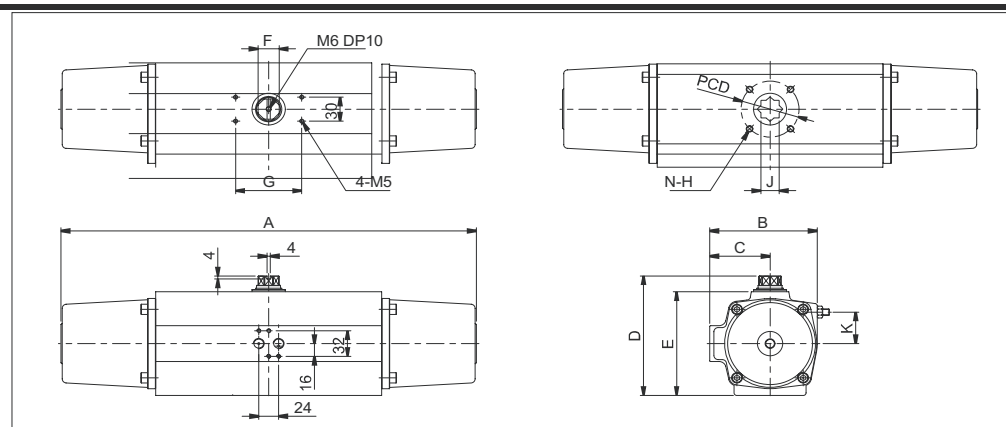

UNIT : mm

MODEL	A	B	C	D	E	F	G	ISO5211	PCD	N-H	J	DP	K	WEIGHT
PS45	226	73	42	91	71	11.4	80	F03/F05/F07	35/50/70	4-M5/M6	11X11	15	19.5	
PS50	255	73	42	91	71	11.4	80	F03/F05/F07	35/50/70	4-M5/M6	11X11	15	19.5	1.7
PS55	281	96	55	112	92	17	80	F05/F07	50/70	4-M6/M8	17X17	20	26	
PS70	330	96	55	112	92	17	80	F05/F07	50/70	4-M6/M8	17X17	20	26	3.5
PS75	422	130	73	150	130	25.4	80	F07/F10	70/102	4-M8/M10	22X22	30	39.5	
PS85	423	110	62	130	110	22	80	F05/F07	50/70	4-M6/M8	17X17	25	33	5.5
PS100	499	130	73	150	130	25.4	80	F07/F10	70/102	4-M8/M10	22X22	30	39.5	10
PS125	629	159	88	182	162	28.6	80	F10/F12	102/125	4-M10/M12	27X27	35	47.5	18
PS160	744	195	105	240	210	34	80/130	F10/F14	102/140	4-M10/M16	36X36	60	62	35.5
PS200	869	243	130	292	262	42.5	80/130	F12/F16	125/165	4-M12/M20	46X46	60	77.5	73

EXPLODED VIEW

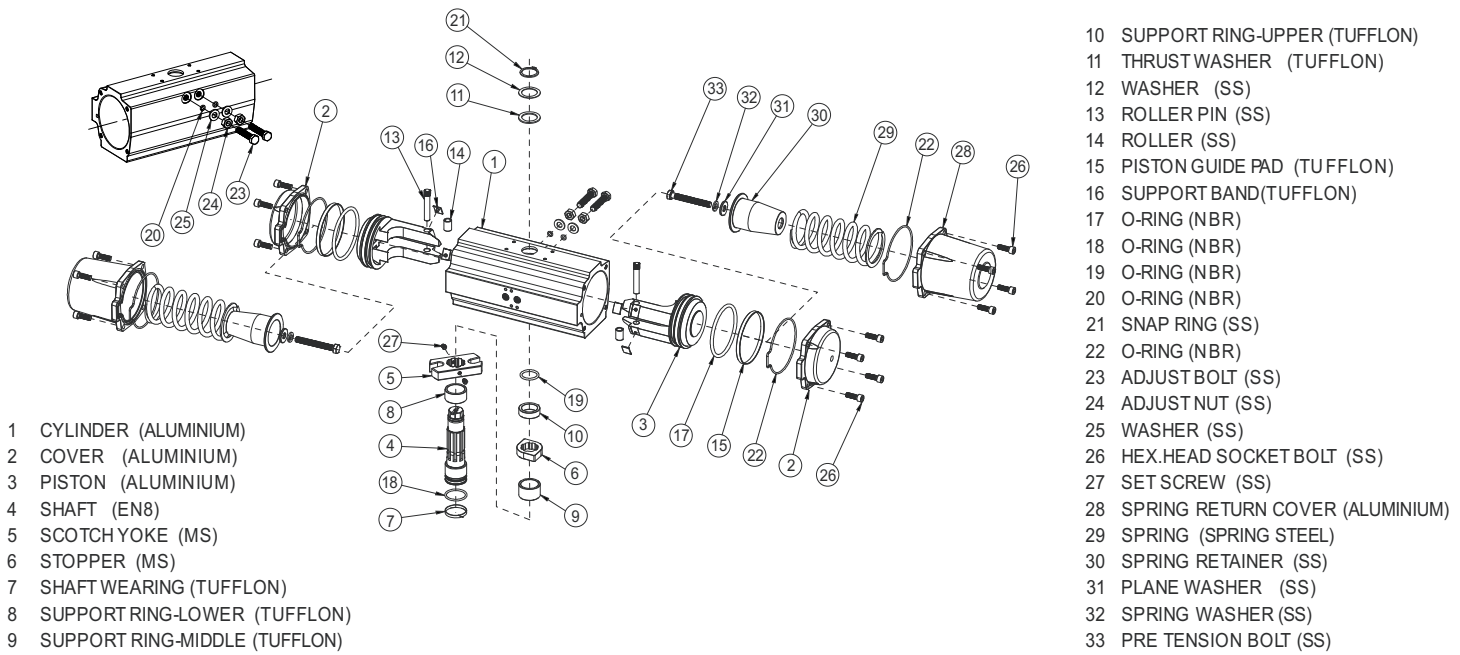

PD40 (RACK & PINION)

OUTPUT TORQUE

PD40 : DOUBLE ACTING (bar, N-m)

PRESSURE	2.8	3.5	4.2	5.5	6	7	8
TORQUE	5.6	7	8.4	11	12	14	16

Please be sure to include appropriate safety factors and various service conditions when sizing.

AIR CONSUMPTION (L, at 5.5 bar)	OPERATING TIME (Sec., at 5.5bar)
0.04	< 0.3

Air Volume :
0.04 Liter

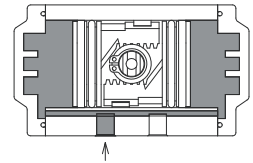

Air Volume :
0.04 Liter

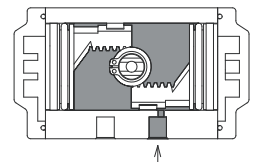

DIMENSIONS

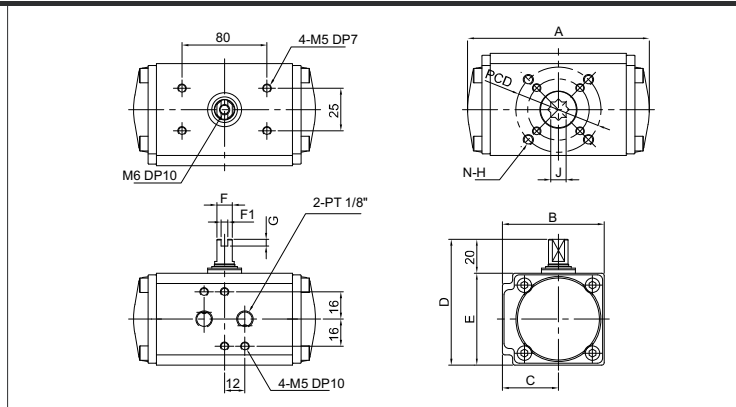

MODEL	A	B	C	D	E	F	F1	G	ISO5211	PCD	N-H	J	DP	WEIGHT
PD 40	107	60	33	74	54	9	4	4	F03/F05	35/50	4-M5/M6	9x9	11	1.1

EXPLODED VIEW

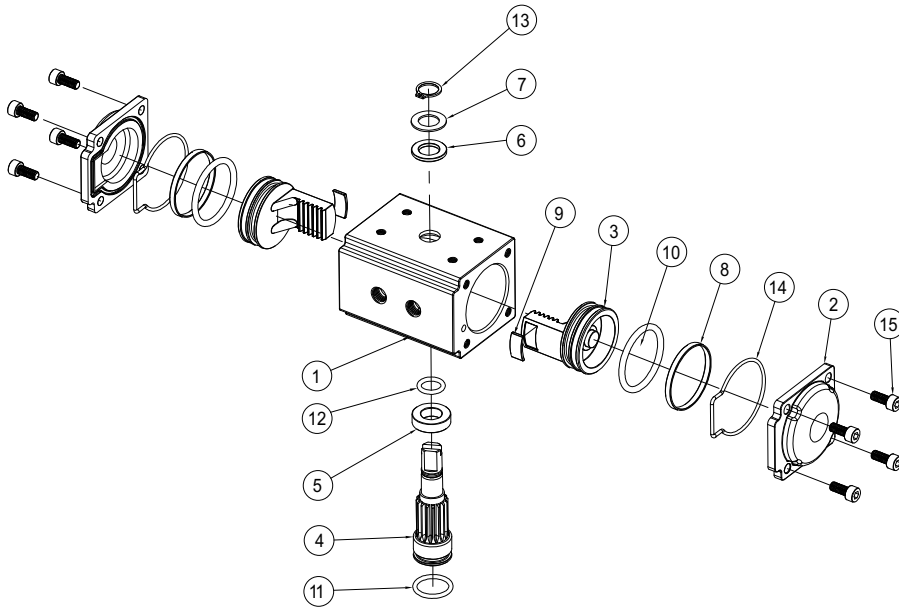

- 1 CYLINDER
- 2 COVER
- 3 PISTONE
- 4 SHAFT
- 5 SUPPORT RING-UPPER
- 6 THRUST WASHER
- 7 WASHER
- 8 SUPPORT BAND
- 9 PISTON GUIDE PAD
- 10 O-RING
- 11 O-RING
- 12 O-RING
- 13 SNAP RING
- 14 O-RING
- 15 SUS WRENCH BOLT

ACCESSORIES

ITS Series Position Monitoring Switch Box

ITS 100 Series (Weather Proof)



SPECIFICATION	STANDARD OPTION
Enclosure	Weather proof IP67, O-ring sealed
Outside coating	Epoxy-Polyester inside and outside
Ambient temperature	-20°C ~ +80°C
Cable entries	2 - PT1/2", other standard threads
Terminal block	8 nos of terminal strips
Position indicator	Dome type 0°~90°
Mounting bracket	Stainless steel acc. to VDI/VDE 3845, NAMUR, SS1, SS2 as standard
Switches(Sensors)	2-SPDT mechanical switch(Form C)

ITS 300 Series (Explosion Proof)

Suitable for valves and actuators in hazardous area applications conforms to EN50014 and 50018, also suitable in Zone 1 and 2



SPECIFICATION	STANDARD OPTION
Enclosure	Explosion proof Ex d IIC T6, IP67, O-ring sealed
Outside coating	Epoxy-Polyester outside against corrosion
Ambient temperature	-20°C ~ +80°C
Cable entries	2 - PF3/4", other standard threads
Terminal block	8 nos of terminal strips
Position indicator	Dome type 0°~90°
Mounting bracket	Stainless steel acc. to VDI/VDE 3845, NAMUR, SS1, SS2 as standard
Switches(Sensors)	2-SPDT mechanical switch(Form C)

ITS 500 Series

Special stainless steel housig (316L or Duplex) for extremely corrosive environmental conditions & for off-shore applications.

Other specifications are shared with the ITS 300 series except for enclosure & coating.



Electro-Pneumatic Positioner



EPL (Linear Type)



EPR (Rotary Type)

EPL / EPR (Mechanical Type)

FEATURE

- Precise calibration with simple SPAN and ZERO adjustments
- Simple conversion to direct acting or reverse acting
- 1/2 split range available
- Rugged aluminum housing with corrosion-resistant coating
- Stainless steel gauges standard
- Restricted pilot valve orifice kit for small actuators included

*Options available

- Position transmitter (4-20mA output signal)
- Two limit switches (open and close)

SSL / SSR (Electronic Smart Type)

FEATURE

- Auto-calibration for optimum conditions
- Easy operation with four key pads and full text graphical LCD
- Single and double acting actuators
- Pressure regulator built in to eliminate variations in supply air pressure
- Economical energy saving
- Mounting on linear actuators according to IEC 534
- Mounting on rotary actuators according to VDI / VDE 3845

*Options available

- Position transmitter (4-20mA output signal)
- Gauge block with two stainless pressure gauges
- Explosion proof type (Ex d IIB T6, Exia IIC T6)
- HART communication (FSK)



SSL (Linear Type)



SSR (Rotary Type)



IPC

IPC (I/P CONVERTER)

FEATURE

- Pressure regulator built in to eliminate variations in supply air pressure
- Low air consumption due to piezo electric micro-valve
- Explosion proof type (please contact for details)

Solenoid Valve

- Robust, reliable patented 2 piston / 4 pillar poppet valve design provides bubble-tight shut-off for millions of cycles
- 5/2 function or 3/2 function selectable via 180o turn of the patented rotary sealing plate
- Direct NAMUR standard mounting
- Corrosion and impact resistant glass fiber reinforced composite material
- Low maintenance through non lubrication design
- High air flow ($C_v > 1,1$) and fast response
- Wide operating temperature range : -40°C to 50°C (-40°F to 125°F)
- Pressure range 2.5 - 8 Bar (35-120 PSI)

- Weatherproof IP67
- NEMA types 1, 2, 3, 3S, 4 and 4X & CE Certified
- ATEX Ex Series
- Ex-Proof Series
- Intrinsically Safe Series
- Standard Series

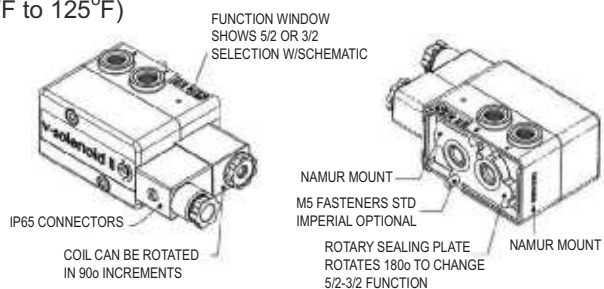

ACCESSORIES

Declutchable Gear Box

		ALUMINUM			DUCTILE IRON		
MODEL NO		ITG 050	ITG 060	ITG 080	ITG 090	ITG 100	ITG 200
Output Torque		300 Nm	500 Nm	800 Nm	2,600 Nm	4,700 Nm	7,800 Nm
Top Flange (ISO 5211) (F1/F2)		F07 / F10	F10 / F12	F12 / F14	F16(Op:F14)	F20(Op:F16)	F25(Op:F20)
Reduction Ratio		40 : 1	45 : 1	48 : 1	41 : 1	47 : 1	54 : 1
Mechanical Advantage		12	13.5	14.4	14.4	16.5	18.9
Number of Handwheel Turns		10 Turns	11.3 Turns	12 Turns	10.3 Turns	11.8 Turns	13.5 Turns
Available Max. (Valve Shaft)	Diameter(Ø)	22	32	40	65	75	95
	Square(▨)	17	27	36	54	62	75
	Two Flat	17	27	36	54	62	75
Handwheel Diameter		300	350	450	500	560	630
Bottom Flange (ISO 5211)		F07 / F10	F10 / F12	F12	F16 (Op:F14)	F20 (Op:F16)	F25 (Op:F20)
Weight		5.5 Kgs	9.3 Kgs	15.5 Kgs	26 Kgs	35 Kgs	74 Kgs
Applicable Pneumatic Actuator		PD50/70/85, PS50/70	PD100, PS85/100	PD125, PS125	PD140/160, PS140	PD200, PS160	PS200

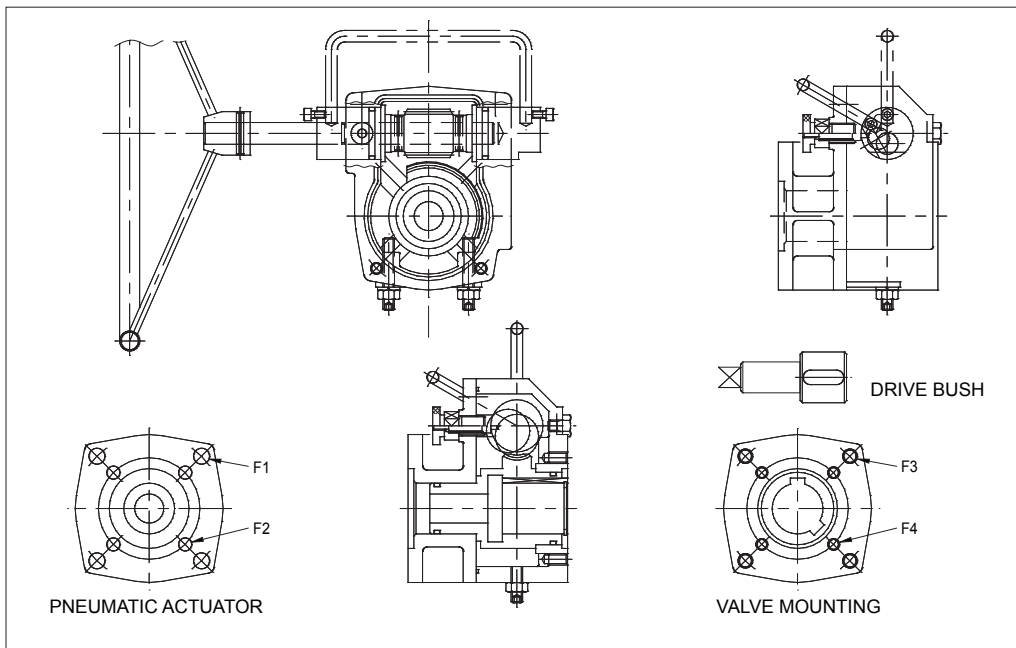

* Details are provided upon request.

Manual Handwheel



-Simple and Compact in size and weight

* The details of this catalog are subject to change without prior notification.

The details of this catalog are subject to change without prior notification.

 **CONTROLS Co., Ltd.**

Website : <http://www.i-tork.com>

REGIONAL SALES OFFICE - South East Asia

AHF Engineering Sdn. Bhd. (Company Reg. No: 200901015119)

No 5, Jalan USJ 1/31, Taman Subang Permai, 47600 Subang Jaya, Selangor D.E., MALAYSIA

Tel. (Office) : +603-8024-0940 Fax (Office) : +603-8024-0941 Email : cky@ahfengineering.com

© I-TORK® Controls Co., Ltd. All rights reserved. ICS-CA-1603
